

A - A

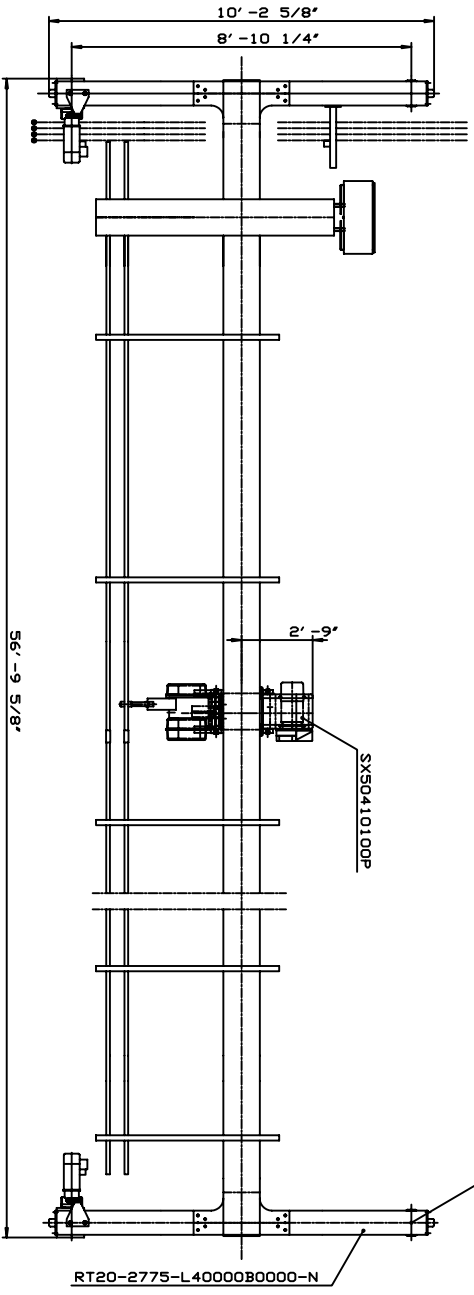

MAX. STATIC WHEEL LOAD 13.5 KIPS

TECHNICAL DATA

LOAD.....	10 Ton
SPAN.....	56'-0"
LIFTING HEIGHT.....	18'-5 3/4"
HOISTING SPEED.....	19.7/3.3 ft/min 2-SPEED
TROLLEY SPEED.....	65 ft/min STEPLESS
BRIDGE SPEED.....	100 ft/min STEPLESS
WEIGHT OF TROLLEY.....	1340 lbs
WEIGHT OF BRIDGE.....	12270 lbs
POWER SUPPLY.....	460 V / 115 V / 60 HZ
CRANE GROUP.....	CMAA C

RT20-2775-L40000B0000-N

Custom Steel Inc.
 318 Ross Avenue
 Schofield, Wisconsin 54476
 PH: (715) 355-1300 FAX: (715) 355-5200